



QUBIG GmbH
Balanstr. 57 | 81541 Munich
GERMANY
Tel. +49-89-2302-9101
www.qubig.com

SMD LIGHT MODULATORS

for
ultra compact
Laser systems

**CUTTING-EDGE
DEVELOPMENTS**
at QUBIG

Resonance frequencies:	4-500MHz 5-10GHz
Quality factor (Q):	> 100 (typ.)
Spectral range:	360nm, ... ,4um
Laser damage (LIDT):	~ 500mW/mm @ 532nm
Wavefront distortion:	< $\lambda/6$ @ 633nm (typ.)
Crystal aperture:	1.3x1.3mm ² ; 2x2mm ²
Max. RF power:	~ 0.5W (27dBm)
Input impedance:	50ohm (typ.)
Dimensions:	7x7x10mm ²
Mounting:	Solder or glue



Key prospect:

The union of electronics with optics and their miniaturisation plays a much bigger role than just the massive reduction in complexity, size and susceptibility in today's industrial plants and systems. An establishment of Quantum Technology (QT) in industry, aerospace or daily life will fail without considering the industrial implementation of those highly sensitive and complex systems. QUBIG offers a new family of free-space light modulators compatible with SMD mounting technology to facilitate the integration into complex systems.

SMD LIGHT MODULATORS

for ultra compact Laser systems



SMD EOMS

The modulators are built for easy integration into electronic and optoelectronic setups. They are easy to implement on printed circuit boards (PCB) by either soldering, gluing, or wire bonding and show an intrinsic small alignment sensitivity. Additional options for RAM suppression, frequency fine-tuning, high optical power handling, or high modulation efficiency are available.

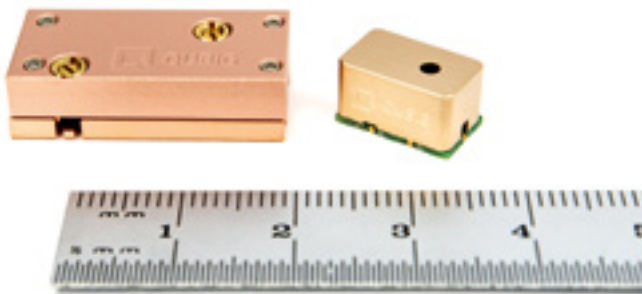

Fig. 1 | SMD compatible phase modulators resonant at 20 MHz (right) and 6.8 GHz (left).

SMD EOMS + DRIVER

The compact form factor and SMD mounting allow for the integration of the light modulators directly on the RF-source electronics powered by a USB connection. This package not only eliminates bulky drivers but also improves the overall efficiency since there are no transmission losses in coaxial cables for high frequencies.



Fig. 2 | SMD compatible phase modulators with integrated driver resonant at 20 MHz (right) and 6.8 GHz (left).

OPTO-ELECTRONIC INTEGRATION

Ultra-compact electro-optical modulators can be integrated into robust electro-optical assemblies that offer a high degree of complexity with minimum dimensions. For instance, Fig.3 shows a compact EOM integrated inside an ultra-narrow linewidth diode laser module developed by the Ferdinand Braun Institute and Fig. 4 shows a compact Laser Conditioning Module for Frequency-modulation spectroscopy (LCM-FM) with an integrated SMD EOM.



Fig. 3 | SMD EOM integrated inside an ultra-narrow linewidth diode laser module.

The compact LCF-FM module (15x6x10 cm³) contains a tunable SMD EOM working at 20 MHz to generate an error signal via FM-spectroscopy of an alkali metal. QUBIG currently offers Cs and Rb references and other elements are available on request.



Fig. 4 | Laser Conditioning Module for Frequency-Modulated spectroscopy.



QUBIG GmbH
Balanstr. 57 | 81541 Munich
GERMANY
Tel. +49-89-2302-9101
www.qubig.com

LASER FREQUENCY OFFSET-LOCK

for
dynamic laser
frequency control

**CUTTING-EDGE
DEVELOPMENTS**
at QUBIG

QPLL SERIES

Frequency-offset lock system

TECHNICAL SPECS:

- Continuous tuning range: 0.5–10 GHz
- Sweep rate: 2 GHz/s
- Spectral range: 280–800 nm
- Features: Phase lock, FPGA-based PID

APPLICATIONS

- High resolution spectroscopy • LiDAR
- Metrology • Interferometry • Laser cooling
- Raman/coherent spectroscopy
- Non-destructive testing



Key prospect:

Laser frequency control is a key element in the implementation of high precision Quantum technologies. The QPLL series from QUBIG accomplishes a robust and versatile frequency offset lock between two lasers (a “reference” and “tunable” Laser) that allows either continuous relative frequency tuning over a 10 GHz range within seconds or large mutual frequency offsets up to 100 GHz. At its core lie QUBIG’s free-space light modulators that make the system compatible with a broad laser spectrum from UV (360 nm) to the NIR (800 nm) at very low optical losses.

LASER FREQUENCY OFFSET-LOCK

for dynamic laser frequency control



FREQUENCY OFFSET LOCK USING AN EOM

The use of an electro-optic phase modulator offers a dynamic tool for the control of the relative frequency of two lasers. The idea is to lock the frequency of a tunable laser (L2) onto a sideband generated in a reference laser (L1) using an electro-optic modulator. By changing the modulation frequency of the EOM (f_{mod}), the frequency offset (f_{offset}) can be precisely adjusted.

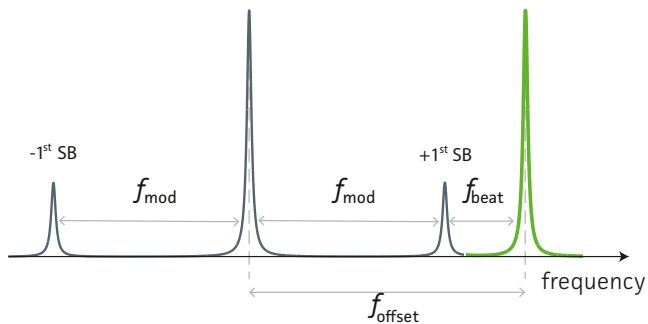

Fig. 1 | Frequency offset lock using an electro-optic modulator working principle.

In the QPLL series, the light of a reference laser is modulated using an EOM and combined with the tunable laser (L2). The beat note between the sideband and the tunable laser (f_{beat}) is compared to a stable frequency reference (f_{ref}) and the deviation (Error) is used to stabilize the frequency of the tunable laser.

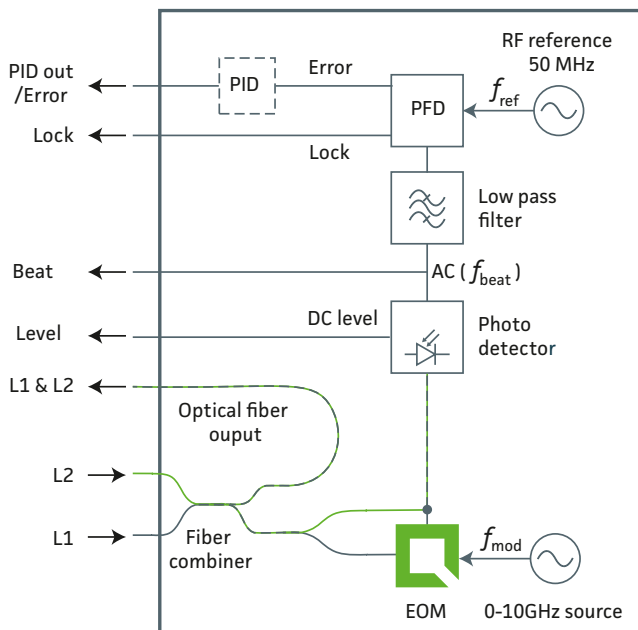

Fig. 2 | Block diagram for the QPLL series for dynamic frequency offset lock using an EOM.

QPLL-C SERIES

The QPLL-C series from QUBIG offers a compact and robust system to create a high-precision frequency offset lock. The core of the system is a broadband phase modulator (TWP-series) that allows for continuous tuning of a laser's frequency over 10 GHz. It allows a wide frequency reference without the need for an expensive optical frequency comb, wavemeter, or complex transfer cavity. It is ideal for UV light, and it is a perfect combination with mode-hop-free DFB lasers.

KEY FEATURES

- continuous frequency tuning over 10 GHz
- sweep rate faster than 2 GHz/s
- integrated FPGA-based PID

OPTIONS

- optical phase lock (between L1 & L2)
- up to 20 GHz continuous frequency tuning
- OEM/Rack module

QPLL-R SERIES

Different from the QPLL-C series, the core of the QPLL-R series is a highly efficient resonant phase modulator (PM10/11-series) in which multiple sidebands are available for an offset lock.

KEY FEATURES

- large frequency offsets up to 100 GHz
- precise electronic frequency adjustment
- ideal for the UV spectrum

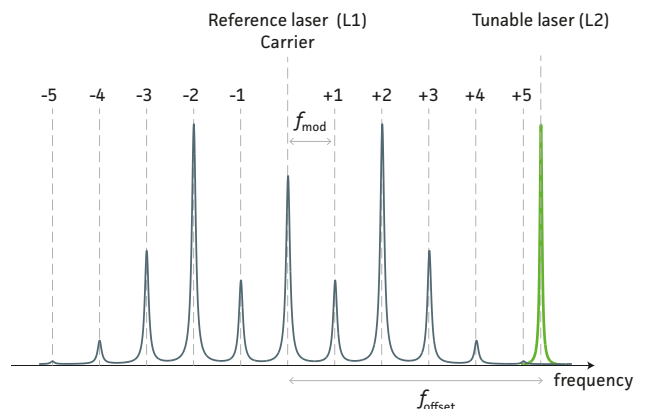

Fig. 3 | Frequency offset lock using a high-efficiency resonant electro-optic modulator. Higher order sidebands are used to reach large frequency offsets.